

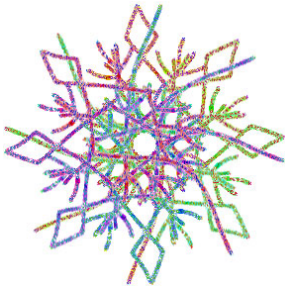

**MARC LABORATORY [WWW]
LAB GUIDE
VER 4.1 - WINTER 2002**

V 4.1 © 2002 Robert E. Marc

These protocols may be copied and distributed for educational and non-profit purposes as long as acknowledgement of our copyright is included in every instance of use. They may not be sold or distributed for commercial gain. As conditions of use are outside our control, we make no warranties, express or implied, and assume no liability in connection with use of these protocols.



Document validated 15 Feb 2002

Table of contents

Topic	Page
Abbreviations	3
Atomic and Molecular Weights	4
Salines	5
Buffers	7
Fixatives	8
Uranyl acetate en bloc	9
Vibratome immunocytochemistry	10
Dehydration and embedding	11
Grid staining UrAc and Pb citrate	12
Deplasticizing	13
Silver immunocytochemistry	14
Fluorescence immunocytochemistry	15
EM immunocytochemistry	16
Antigen immunoblots	17
Fabrication of amino acid antigens	19
Fish IO AGB injection protocols	20
Rabbit retinal incubation protocol	22
Autoradiography protocol	24
ICC slide record blanks	28
ARG slide record blanks	29

Abbreviations

General Abbreviations

aa	amino acid
Ab	antibody
BSA	Bovine serum albumin
DDSA	dodecenylsuccinic anhydride
dH ₂ O	deionized water
DMP-30	Tri(dimethylamino)phenol
Eponate, Medcast	Proprietary names of a thermosetting epoxide resin
EtOH	Ethanol
GA	glutaraldehyde
GAR	Goat anti-rabbit IgG
GAR-gold	GAR coated gold granules
gfs	goldfish saline
glut	glutaraldehyde
GS	Goat serum
GSTPBS	Goat serum in TPBS
GSTPBSTX	Goat serum in TPBS + 0.3% TX-100
h	hours
IPF	Immobilon-P filter
m	minutes
MeOH	Methanol
NH ₂ OH	hydroxylamine
PB	phosphate buffer pH 7.4
PF	paraformaldehyde
RT	room temperature
s	seconds
TPBS	(10 mM PB + 0.01% thimerosol in 0.9% NaCl, pH 7.4)
TX-100	Kodak Triton X-100

Micromolecule Abbreviations

A	alanine
γ	GABA - also YY
C	cysteine
D	aspartate
E	glutamate
F	phenylalanine
G	glycine
H	histidine
I	isoleucine
J	GSH
K	lysine
L	leucine
M	methionine
N	asparagine

Micromolecule Abbreviations

O	ornithine
P	proline
Q	glutamine
R	arginine
S	serine
T	threonine
TT	taurine - also τ
τ	taurine - also TT
V	valine
W	tryptophan
X	citrulline
Y	tyrosine
YY	GABA - also γ

Atomic Weights

Ag	108	K	39
Au	197	Li	6.9
Ba	137	Mg	24
C	12	Mn	55
Ca	40	Na	23
Cl	35	Os	190
Co	59	P	31
Cs	132	S	32
F	19	Sr	88
Fe	56		
I	127		

Molecular Weights

NaCl	58
NaHCO ₃	84
Na ₂ HPO ₄	142
NaH ₂ PO ₄ H ₂ O	138
LiCl	42
KCl	74.5
KH ₂ PO ₄	136
CaCl ₂ H ₂ O	147
MgSO ₄	120
Dextrose	180
Na ₂ EDTA	372
alanine	89
arginine	174
asparagine	132
aspartate	133
cysteine	121
glutamine	146
glutamate	147
glycine	75
histidine	155
isoleucine	131
leucine	131
lysine	146
methionine	149
phenylalanine	165
proline	115
serine	105
threonine	119
tryptophan	204
tyrosine	181
valine	117

Salines

Saline 1. Hepes Buffered Teleost Saline

Stock Solutions: NaCl = 4 M; All others = 1 M

Add solutions in this sequence

Agent	final mM	cc STOCK FOR 100 cc SALINE
NaCl	130	3.25
HEPES	10	1.0 (adjust pH at this point to about 7.4)
KCl	4	0.4
CaCl ₂	1	0.1 (add slowly with stirring)
MgSO ₄	1	0.1 (add slowly with stirring)
NaHCO ₃	2	0.2 (dissolve in a little dH ₂ O and add slowly)
NaH ₂ PO ₄	0.4	0.04
Na ₂ HPO ₄	1	0.1
GLUCOSE	10	1.0
check pH and adjust to 7.5-7.8 if necessary		

Saline 2. High Potassium Teleost Saline: Substitutions for Saline 1

Agent	mM	cc STOCK FOR 100 cc SALINE
NaCl	80	2.0
KCl	50	5.0

Saline 3. AGB teleost saline – 10 mM AGB: Add 228 mg AGB SO₄ to Saline 1.

Saline 4. HEPES-Ames rabbit saline

Start with 900 ml dH₂O

Add with stirring until each is dissolved:

Agent	mg	Notes
NaCl	7010	
KCl	231	
D-glucose	1081	
HEPES	15 cc	stock 1 M HEPES
>>>>>>	>>>>>>	adjust pH to 7.3 at this point
>		
CaCl ₂ ·H ₂ O	169	
MgSO ₄	150	
KH ₂ PO ₄	68	
NaHCO ₃	661	

Bring up to 1000 ml with dH₂O

Sterile filter and store in refrigerator

Saline 5. HEPES-Ames rabbit saline – 5 mM AGB: Add 114 mg AGB SO₄ to Saline 4.

Saline 6. Full bicarbonate-Ames saline

Start with 900 ml dH₂O

Add with stirring until each is dissolved:

Agent	mg	Notes
CaCl ₂ ·H ₂ O	169	
MgSO ₄	150	
KCl	231	
KH ₂ PO ₄	68	
NaCl	7010	
D-glucose	1081	

Gas with 100% CO₂

Add 1900 mg Na HCO₃ with stirring (MW 84)

Add 1cc additive concentrate (see below)

Bring up to 1000 ml with dH₂O

Equilibrate with 95% O₂ / 5% CO₂ at 37 °C before use

Concentrated vials of amino acids and vitamins for Ames Medium

To 100 ml dH₂O, add with stirring, aliquot into 1 cc vials and freeze.

Agent	mg	Agent	mg
L-alanine	240	L-Tryptophan	49
L-arginine	420	L-Tyrosine	211
L-asparagine	84	L-Valine	176
L-aspartate	12	Na Ascorbate	1796
L-cystine-2HCl	6	D-biotin	10
L-glutamine	7300	Choline Cl	70
Na L-glutamate	118	Folic Acid	10
Glycine	45	myo-Inositol	2720
L-Histidine	251	Niacinamide	10
L-Isoleucine	58	D-Pantothenate	10
L-Leucine	144	Pyridoxal HCl	10
L-lysine HCl	365	Riboflavin	1
L-methionine	39	Thiamine HCl	10
L-Phenylalanine	132	Cytidine	73
L-Proline	7	Hypoxanthine	82
L-Serine	252	Na Pyruvate	1333
Taurine	75	Thymidine	24
L-Threonine	333	Uridine	73

Buffers

Buffer 1. Sorenson's PB (see Hayat table for other pH solutions)

Stock A = 28.4 g dibasic/anhydrous Na phosphate (Na_2HPO_4) or
35.6 g dibasic Na phosphate ($\text{Na}_2\text{HPO}_4 \cdot 2\text{H}_2\text{O}$) or
53.7 g dibasic Na phosphate ($\text{Na}_2\text{HPO}_4 \cdot 7\text{H}_2\text{O}$) or
71.6 g dibasic Na phosphate ($\text{Na}_2\text{HPO}_4 \cdot 12\text{H}_2\text{O}$)
in 1000 ml dH_2O = 0.2 M

Stock B = 27.6 g monobasic Na phosphate ($\text{NaH}_2\text{PO}_4 \cdot \text{H}_2\text{O}$) or
31.2 g monobasic Na phosphate ($\text{NaH}_2\text{PO}_4 \cdot 2\text{H}_2\text{O}$)
in 1000 ml dH_2O = 0.2 M

pH	Solution A	Solution B	A:B
6.0	6.15	43.85	1.00:7.13
6.6	18.75	31.25	1.00:1.67
7.0	30.5	19.5	1.56:1.00
7.4	40.5	9.5	4.26:1.00
8.0	47.35	2.65	17.9:1.00

Standard 4 L bottle of 0.2 M PB

1. Dissolve 92 g dibasic anhydrous Na phosphate (Na_2HPO_4) in 1000 ml hot dH_2O
2. Dissolve 92 g monobasic Na phosphate ($\text{NaH}_2\text{PO}_4 \cdot \text{H}_2\text{O}$) in 1000 ml dH_2O
3. Mix and dilute to 4000 ml.
4. Final concentration = 0.2 M; pH \approx 7.4; check and adjust to between 7.3-7.5.

Fixatives

Fixative 1: 1% Paraformaldehyde / 2.5% glutaraldehyde in PB – 100 ml

- 50 cc 0.2 M PB stock for mammals, 40 cc for teleosts
 - 10 cc 25% Biological Grade glutaraldehyde
 - 5 cc Shandon 18.3% formaldehyde
 - 3 g sucrose
 - dilute to 100 cc with dH₂O
-

Fixative 2: 1% Paraformaldehyde / 2.5% glutaraldehyde in buffer for electron microscopy– 50 ml

- 10% paraformaldehyde stock
 - 1. 4 drops 0.2 N NaOH in 10 cc dH₂O in scintillation vial
 - 2. 1 g pure powdered paraformaldehyde
 - 3. Bring to near boiling in fume hood with stirring
 - 4. Stop when clear, cool to RT and filter
 - 50 cc full fixative
 - 1. 10 cc dH₂O
 - 2. 5 cc 10% PF (from above)
 - 3. 5 cc 25% glutaraldehyde
 - 4. Buffer options
 - a. Cacodylate: 2.5 cc 2 M for mammals, 2 cc for teleosts
 - b. PB: 25 cc 0.2 M for mammals, 20 cc for teleosts
 - 5. 1.5 g sucrose
 - 6. 3 cc 0.02% CaCl₂
 - 7. Dilute to 50 cc with dH₂O
 - 8. Check pH (7.4) and adjust if necessary
-

Fixative 3: 4% Paraformaldehyde / X % glutaraldehyde in buffer for immunocytochemistry – 50 ml

- 20% paraformaldehyde stock
 - 1. 8 drops 0.2 N NaOH in 10 cc dH₂O in scintillation vial
 - 2. 2 g pure powdered paraformaldehyde
 - 3. Bring to near boiling in fume hood with stirring
 - 4. Stop when clear, cool to RT and filter
- 50 cc full fixative
 - 1. 10 cc dH₂O
 - 2. 10 cc 20% PF (from above)
 - 3. Buffer options
 - a. Cacodylate: 2.5 cc 2 M for mammals, 2 cc for teleosts
 - b. PB: 25 cc 0.2 M for mammals, 20 cc for teleosts
 - 4. 1.5 g sucrose
 - 5. 3 cc 0.02% CaCl₂
 - 6. Dilute to 50 cc with dH₂O
 - 7. Check pH (7.4) and adjust if necessary
 - 8. Add X μ l 25% glutaraldehyde for the following final concentration

% glutaraldehyde	μ l 25% to add
0.1	200
0.05	100
0.02	40
0.01	20

Uranyl Acetate *en bloc* Stain

This is used to bring out unit membranes. The stain is used just after osmium post-fixation and before dehydration. It usually dissolves glycogen or renders it unstainable.

STOCK SOLUTIONS:

pH 5.15 Maleate buffer: 11.6 g maleate/500 ml dH₂O, adjusted to pH 5.15 with NaOH

pH 6.00 Maleate buffer: 11.6 g maleate/500 ml dH₂O, adjusted to pH 6.00 with NaOH

1% uranyl acetate in pH 6.00 maleate (pH drops on addition of uranyl acetate; dissolve by sonication)

PROCEDURE:

1. After osmication, wash tissue blocs in pH 5.15 maleate buffer (3 × 5 min). If phosphate buffer was used previously, more extensive rinsing will be necessary to prevent precipitation of uranyl phosphate. For thin retinal tissue, 3 × 15 min should suffice.
2. Stain in 1% uranyl acetate in pH 6.00 maleate for 1 hr at room temperature wrapped in foil (i.e. dark).
3. Wash in pH 5.15 maleate buffer (3 × 5 min).
4. Proceed to dehydration.

REFERENCES:

Farquahar and Palade, J Cell Bio 26:263, 1965.

Trelstad, Revel and Hay, J Cell Bio c-6, 1966.

Marc Lab Vibratome Immunocytochemical Procedures

MARC LAB: 1984;1985/1998 REVISION
Procedures at RT unless noted otherwise

STEP	TIME	SOLUTION	ACTION
1	60 m	fixative	
2	overnight	PBS	4° C
3	30 m	4% Lo temp agarose	Embed drained tissue in agarose @ 35-40° C, chill @ 4° C
4	Section at 50 µm into chilled PBS.		Depending on antigen, tissues may be stored in PBS at 4° C.
5	60 m	25 mM NH ₂ OH in PBS	
6	10 m	PBS	
7	60 m	3% GSTPBSTX	On rotator
8	10s PBS rinse		
9	overnight	1° Ab in 1% GSTPBSTX	On rotator
10	2 x 1 h rinse	2 changes TPBSTX	On rotator
11	60 m	2° Ab in 1% GSTPBSTX	On rotator
12	overnight	TPBSTX	On rotator
13	30 m	PAP 1:50 in 1% GSTPBSTX	On rotator
14	60 m	PBS	On rotator
15	5 m	3 mg DAB in 5 ml PBS	
16	7 m	3 mg DAB + 25 µl 3% H ₂ O ₂ in 5 ml PBS	
17	Rinse and store	cold PBS	
18	15 m	1% OsO ₄ in 0.1 M PB	Optional
19	dehydrate amd embed	Epon	Optional

See also Marc et al., 1988, J. Neurosci.

Standard Marc Lab Dehydration and Embedding Procedure

Stock Solutions:

100% Acetone

100% anhydrous MeOH and 75%, 85%, 95% MeOH in dH₂O

DMP30

Eponate or Medcast resin

DDSA

Active resin: Mix up fresh or thaw from freezer. Work quickly and prevent any components from hydrating. Keep off skin as these components are thought to cause contact dermatitis and their synthesis involves known carcinogens. Mix up in the hood

Mix 2 parts DDSA and 1 part Medcast (by weight or volume) in a tripour beaker with a wooden spatula until the solution is clear (2-5 minutes)

Add 0.6 ml DMP30 per 30 ml resin (e.g. add 1.2 ml DMP to 60 ml DDSA + Eponate)

Mix gently as before until clear (2-5 minutes). Solution will darken some as the activated epoxide begins to bind oxygen.

Use immediately or store in 30-60 cc syringe in the freezer. Expel all air before freezing and plug syringe with a wooden dowel. Do not cap with a needle or plastic cover. They leak air.

Schedule:

Time	Solution (all volumes \approx 5-10 ml unless noted otherwise)
10 m	0.1 M PB
10 m	75% MeOH
10 m	85% MeOH
10 m	95% MeOH
10 m	100% MeOH
10 m	100% MeOH
10 m	100% Acetone
10 m	100% Acetone
60 m	50% resin in acetone (can be skipped if 75% goes overnight)
4-20 h	75% resin in acetone
60 m	100% resin

embed samples in fresh resin in molds and cure at 60-65 °C overnight

Grid Staining with Uranyl Acetate

1. Make a 3% aqueous solution of uranyl acetate in filtered ultrapure water.
2. Sonicate until dissolved.
3. Place droplets on dental wax in a petri dish with a wet Kimwipe at the side.
4. Float grids section-side down in the covered dish for 60 minutes.
5. Rinse in ultrapure water.

Grid Staining with Lead Citrate

6. Bring 250 ml ultrapure water to boil in a glass flask. Pour into a 200 ml tissue culture bottle and cap. Allow to cool to near room temperature. You may cool it by immersion.
7. Prepare a 5 N aqueous solution of NaOH (20 g / 100 cc) as a stock wash. Place 50 ml boiled ultrapure water in a 200 ml tissue culture flask and add 20 g of NaOH. Shake until dissolved and dilute to 100 ml.
8. Rinse a 100 ml plastic Tripour® beaker and a 10 ml plastic syringe and plunger in 100 ml ultrapure water containing 2-3 drops of stock 5 N NaOH, followed by 10 exchanges of ultrapure deionized water. Shake out the excess water.
9. Add 20 mg lead citrate to 10 ml of water in the Tripour® beaker, followed by a few drops of NaOH while stirring gently with a spin bar. Add just enough NaOH to dissolve the lead citrate – no more – usually 4 drops.
10. Add the dissolved lead citrate to the syringe, expel all the air and cap it with a butterfly needle and tube clamped with a hemostat.
11. To stain, discard the first several drops from the tip of the tube. Place a drops on a piece of dental wax in a petri dish. Place 6-9 pellets of NaOH in a ring around the droplets. Float the grids section-side down in the covered dish for 1-30 minutes as needed.
12. Rinse in ultrapure water.

Deplasticizing Procedure

STOCK SOLUTIONS

100% EtOH

100% MeOH

Na methoxide ($\text{NaOCH}_3 \bullet 2\text{CH}_3\text{OH}$) or aged Na ethoxide ($\text{NaOCH}_2\text{CH}_3 \bullet 2\text{CH}_3\text{CH}_2\text{OH}$)

Aged Na ethoxide: Place ≈ 1 inch of NaOH pellets in a heavy glass 500-1000 ml bottle with a glass stopper covered in Parafilm. Cover the pellets with ≈ 3 inches of EtOH, seal and place in the hood. Shake daily until the solution becomes dark brown and syrupy (7-14 d), whence it is ready for use. Add replacement EtOH as the stock is used.

Na Methoxide: 50:50 Na methoxide and MeOH

Procedure:

1. Working solution: Dilute stock sodium methoxide/ethoxide 1:4 v/v in anhydrous EtOH. **It is critical that all solutions be absolutely anhydrous. If you doubt the 100% EtOH, don't use it.**
2. Place slides into glass or steel carriers (**no plastic**) and immerse in the working solution. The general etching time is 14 m/ μm and is linear (≈ 30 m for 2 μm , 7 m for 500 nm, 1 m for gold 90 nm sections).
3. Drain the excess solution by blotting the carrier onto a stack of paper towels.
4. Immediately immerse into 100% EtOH or MeOH and wash 2 m. Repeat 2 \times with fresh alcohols.
5. Rinse slides 5 m in running cool tap water
6. Dip slides in dH_2O and air dry.

Immunocytochemical Staining with Gar-gold/silver Intensification

Marc Laboratory, Moran Eye Center, University of Utah
Rev (1991)(1993)(1994)(1995)(1998)

STOCK REAGENTS

- Na Ethoxide/Methoxide
 - Anhydrous EtOH & MeOH
 - PB (0.1 M, pH 7.4), PBT (PB + 0.05% thimerosal, pH 7.4)
 - NaIO₄
 - 1° antibodies
 - GAR-gold 1 nm (Amersham)
 - 1% GSPBT (1% goat serum in PBT)
 - *Silver intensification stock solutions:*
 - Stock A – 114 mg citric acid + 342 mg sodium citrate in 6 ml dH₂O (make fresh)
 - Stock B - 0.5 g hydroquinone in 15 ml dH₂O (make fresh)
 - Stock C - 1% aqueous silver nitrate (use lab stocks)
 - *Silver intensification Working Solution*
 - Make fresh and use within 60 seconds
 - 5 ml Stock A + 1 ml Stock B + 1 ml Stock C, in order
 - Epon
1. 100-1000 nm sections of epoxy resin embedded tissue.
 2. Deplasticize 7 m in 1:4 v/v Na methoxide:anhydrous EtOH for sections < 500 nm (actual rate = 1.5 m / 100 nm). **This step must be anhydrous as H₂O will form NaOH and etch sections away.**
 3. Wash in three 2 m changes of anhydrous MeOH, one 5 m running tap water rinse and a dH₂O dip, dry with Dust-Off.

Treat osmicated tissues 7 m with fresh 1% NaIO₄, 1 m PB, dH₂O dip & dry. Heavily osmicated tissues need ≈ 30 m 1% NaIO₄.

4. Stain with 1° Ab in 1% GSPBT (4 h → overnight), 1 drop (≈ 25-50 μl) per well. Cover with a glass staining tray sealed by plastic wrap to prevent evaporation.
5. Flick off 1° Ab. Dip in 0.1 M PB, rinse 15 m in PB.
6. Dip slides in dH₂O. Dry with Dust-Off. **Do not get propellant on the slides.**
7. Stain 1 h with 2° Ab. 1:50 Amersham 1 nm GAR-gold in 1% GSPBT
8. Flick off 2° Ab. Dip in 0.1 M PB, rinse 1h in PB.
9. Dip in dH₂O. Dry with Dust-Off. Turn on slide warmer and place slides on it.
10. Prepare silver intensification solutions. **Use immediately**, 1 drop/well. It lasts only 10 minutes. Incubate 3-4 m on slide warmer at 28°C.
11. Dip in 5% acetic acid.
12. Wash for 10 m in dH₂O and dry.
13. Cover slip in Epon.

Immunocytochemical Staining with Fluorescence Detection

Marc Laboratory, Moran Eye Center, University of Utah
Rev (1991)(1993)(1994)(1995)(1998)

STOCK REAGENTS

- Na Ethoxide/Methoxide
- Anhydrous EtOH & MeOH
- PB (0.1 M, pH 7.4)
- PBT (PB + 0.05% thimerosal, pH 7.4)
- NaBH₄
- NaIO₄
- 1° antibodies
- GAR-gold 1 nm (Amersham)
- 3% GSPBT (3% goat serum in PBT)
- 1% GSPBT (1% goat serum in PBT)

1. 100-1000 nm sections of epoxy resin embedded tissue.
2. Deplastinize 7 m in 1:4 v/v Na methoxide:anhydrous EtOH for sections < 500 nm (actual rate = 1.5 m / 100 nm). **This step must be anhydrous as H₂O will form NaOH and etch sections away.**
3. Wash in three 2 m changes of anhydrous MeOH, one 5 m running tap water rinse and a dH₂O dip, dry with Dust-Off.

Treat osmicated tissues 7 m with fresh 1% NaIO₄, 1 m PB, dH₂O dip & dry. Heavily osmicated tissues need ≈ 30 m 1% NaIO₄.

4. Wash 30 m in 1% NaBH₄ in dH₂O.
5. Stain with 1° Ab in 1% GSPBT (4 h → overnight), 1 drop (≈ 25-50 μl) per well. Cover with a glass staining tray sealed by plastic wrap to prevent evaporation.
6. Flick off 1° Ab. Dip in 0.1 M PB, rinse 15 m in PB.
7. Dip slides in dH₂O. Dry with Dust-Off. **Do not get propellant on the slides.**
8. Stain 1 h with 2° Ab. 1:100 Amersham Cy3™ R in 1% GSPBT
9. Flick off 2° Ab. Dip in 0.1 M PB, rinse 1h in PB.
10. Dip in dH₂O & dry.
11. Cover slip in Immumount™.

Immunocytochemical Grid Staining for Electron Microscopy

Marc Laboratory, Moran Eye Center, University of Utah

Rev (2000)

STOCK REAGENTS

- Fresh 1% periodic acid (HIO_4) in distilled H_2O
- Fresh 9% metaperiodate (NaIO_4) in distilled H_2O
- PB (0.1 M, pH 7.4)
- PBT (PB + 0.05% thimerosal, pH 7.4)
- GSPBT1 (1% goat serum + PB + 0.05% thimerosal, pH 7.4)
- GSPBT3 (3% goat serum + PB + 0.05% thimerosal, pH 7.4)
- 15 nm gold goat-anti-rabbit IgG (GAR) 1:20 in GSPBT1
- Primary IgGs diluted in GSPBT1

Note deliver all solutions to grids via a syringe with a 0.2 μm filter. Perform all incubations in a covered, humid dish at RT.

1. Ultrathin 60-90 nm sections of epoxy resin embedded tissue on nickel grids or slots.
2. React 7 m with 1% HIO_4 .
3. Rinse by flushing gently for 10 sec with dH_2O .
4. React 15 m with 9% NaIO_4 .
5. Rinse by flushing gently for 10 sec with dH_2O .
6. Block 10 m with GSPBT3.
7. Wick GSPBT3 off and immediately go to step 8. Do not allow to dry.
8. Primary: Label 2 hr with primary IgGs.
9. Rinse by flushing gently for 10 sec with PBT.
10. Wash 15 m in GSPBT1.
11. Rinse by flushing gently for 10 sec with PBT.
12. Secondary: Label 2 hr with GAR
13. Rinse by flushing gently for 10 sec with PBT.
14. Wash 15 m in GSPBT1.
15. Rinse by flushing gently for 10 sec \times 3 with dH_2O .
16. Dry & store.

Options:

- A. Omit steps 2-5. If immunoreactivity is strong, osmication may not impede signals.
- B. Double labeling. Perform all steps and expose grids to paraformaldehyde vapor at 80°C for 1 hr in hood. Repeat steps 5-16 using 30 nm gold GAR.

Antigen Immunoblots

Marc Laboratory, Moran Eye Center, University of Utah

STOCK REAGENTS:

- Anhydrous MeOH
- Artificial amino acid antigen (A4)
- PB
- PBT
- GSPBT (1% & 3%)
- 1° and 2° Ab
- *Silver intensification stock solutions:*
 - Stock A – 114 mg citric acid + 342 mg sodium citrate in 6 ml dH₂O (make fresh)
 - Stock B - 0.5 g hydroquinone in 15 ml dH₂O (make fresh)
 - Stock C - 1% aqueous silver nitrate (use lab stocks)
- *Silver intensification Working Solution*
 - Make fresh and use within 60 seconds
 - 5 ml Stock A + 1 ml Stock B + 1 ml Stock C, in order
- 5% acetic acid

Procedure:

1. Prepare Immobilon-P filter (IPF; Millipore - Read IP protocol) and work area. Use forceps to handle membrane. Do not touch with fingers. Cut a square of IPF no larger than 2 cm X 2 cm.
 - a. Immerse IPF in 100% MeOH for at least 15 s then immerse in dH₂O until ready to use.
 - b. Place stack of 3-4 paper towels on surface and top with Whatman #2 filter paper.
 - c. Saturate the stack with dH₂O.
 - d. Transfer the immersed IPF to the stack.

Do not allow the IPF to air dry before it is placed on the wet filter. Once on the stack, the IPF will lose its surface moisture and this is normal and necessary. Do not rewet the IPF. Keep it moist by keeping the paper stack wet. Important: IPF has two sides. The textured side (an array of indentations) should face down. Smooth out any air bubbles as they will block protein adsorption. Lay both the Whatman and the IPF papers down carefully and gently squeegee out air bubbles with a tongue depressor. It is better to adjust placement of the paper than to squeegee it.

1. A4s should already have been prepared for spotting. Dilute the A4 solution in 1 log unit (10 fold) or 0.5 log unit (3 fold) steps in 1% GSTPBS in microtubes on a rack in front of the wet IPF-stack.
2. Spot the antigens in 2-5 µl droplets in a row, as shown below.

Antigens →	A	B	C	D
Concentrations ↓				
1:1	1	1	1	1
1:10	2	2	2	2
1:100	3	3	3	3
1:1000	4	4	4	4
1:10000	5	5	5	5
1:100000	6	6	6	6

The antigen spot will first sit bead-like on the surface of the paper and then slowly wick down into through the pores. Proteins are bound with very high efficiency to the membrane while the solvent carrier passes through unadsorbed. The finished spot will appear shiny.

3. Cover the entire filter in 3% GSPBT; you will have to leave a rim of clear filter to prevent the serum from wicking off the sides. Allow for complete adsorption. **Note: Choose linker and blocking serum as dictated by primary antibody.**
4. Place the IPF in a weigh boat and cover with 3% GSPBT for 1 hr
5. Drain the blocking solution and add 1° Ab in 1% GSPBT. Incubate 4 h → overnight with shaking.
6. Wash 1 h in 1% GSPBT on the shaker.
7. Place in a fresh boat and cover with 2° Ab (Amersham GAR-Blotting gold) 1:50 in 1% GSPBT for 1 h on the shaker.
8. Wash in PB for 1 hr.
9. Wash with dH₂O 2 X 5 minutes.
10. Prepare fresh working silver intensification solutions.
11. Use the silver solution immediately as it only lasts 10 m. Immerse the filters 5 m RT. If the sample starts to get very black in just a minute or two, you may stop the reaction early, but if it blackens overall at about 5 m, that is generally OK as the background will lighten as the filter is dried.
12. Stop with 5% acetic acid.
13. Wash for 10 m in dH₂O.
14. Place IPF in an uncovered petri dish in 65 °C oven and dry.

Fabrication of Amino Acid Antigens

Marc Laboratory, Moran Eye Center

University of Utah

Rev 1, 11 DEC 1992, 1998

STOCK SOLUTIONS

- Stock BSA: 12 mg BSA (fraction V Sigma) in 2 ml 0.1 M sterile PB (pH 7.4) = 0.6% BSA
MW BSA = 67K, c/ 59 epsilon NH₂ groups, 30-35 available
- Stock OVA: 19 mg OVA in 2 ml 0.1 M sterile PB (pH 7.4)
MW OVA = 43K, c/ 20 groups
- Stock amino acid: 1.0 M in sterile dH₂O
- stock glut = 2.0 M in dH₂O
- PB 0.1 M pH 7.42M glutaraldehyde (MW = 100 g/mole, 1% GA = 100 mM, 4 ml 25% GA + 1 ml H₂O = 20% = 2 M)
- paraformaldehyde if needed (MW monomer = 40 g/mole; 100 μmoles = 100 μl 3% paraformaldehyde)
- 1% NaBH₄ (MW 37.8)

AMINO ACID STOCK SOLUTIONS

MW = mg/ml → 100 μmoles/100 μl = 1 M

compound	MW
β-alanine	89
GABA	103
glutamate	169
glycine	75
taurine	125
NE	205
DA	190
5HT	213
L-TYR	181

Procedure

1. Add 100 μmoles aa (100 ul stock aa) to 2 ml BSA/PB; vortex
2. Add 100 moles GA (50 μl stock GA) to BSA/aa mixture; vort
3. Shake 15 m RT
4. Split into two 10 ml vials, add 100 μl 1.0 M NaBH₄ in sterile dH₂O to one & shake 30 m RT.
5. Centrifuge concentrate in amicon tubes and resuspend each in 2 ml total. Freeze.
6. For immunization, thaw a frozen 2 ml sample, filter sterilize (0.2 μm) into a crytube. Ship on ice.

Comments: The point of this procedure is to generate BSA molecules with most of the accessible lysines Schiff-base linked to GA-aa groups. The objective is to generate antisera that will recognize this "trimer" in histological preparations as this is exactly the linkage generated in conventional tissue fixation. For most amino acids, the BSA conjugate will be composed of simple lysine-glutaraldehyde-aa decoration. However, for glutamine, lysine, arginine or asparagine, the probability of forming lysine-[glutaraldehyde-amino acid]_n oligomers is high. Even so, since the conjugation conditions closely match the expected conditions of intracellular fixation, this oligo-antigen is not a detriment but likely an asset. The purpose of NaBH₄ reduction is to convert the rotationally restricted Schiff's base N=C linkage to a flexible N-C bond. However, some IgGs are able to bind the N=C forms quite effectively. The tactic we have taken is to immunize with a mixture of N=C and N-C antigen forms.

Fish Intraocular AGB Injection Protocols

STOCK SOLUTIONS

5 ml fresh 150 mM aqueous AGB injection solution. Assuming a vitreous volume of 100 μ l, a 6.7 μ l injection should experience a 15-fold dilution, yielding 10 mM intraocular AGB.

AGB = agmatine sulfate, MW 228.3, get AGB from center freezer
mix 171 mg with 5 ml dH₂O
filter through 0.2 μ m syringe filter before use

Procedure

1. Transfer fishes from the animal room to the physiology room in one of the filter tanks.
2. Load two Hamilton 10-25 μ l syringes, one with each solution.
3. Anesthetize one fish in the MS 222 tank with fresh solution made according to instructions on the tank. When the animal is immobile and not respiring actively, remove with a wet paper towel and lay on its side. Inject the eye with 6.7 μ l of AGB solution with the Hamilton syringe, using a fresh 27 Ga needle. Use the tip of the syringe to rotate the eye slightly to expose the posterior pole and inject behind the limbus (the junction between the sclera and the anterior segment). Work the tip into the eye so that you are sure it is behind the lens and you can see it. The injection should take 20-40 seconds to allow relaxation of chamber pressure.

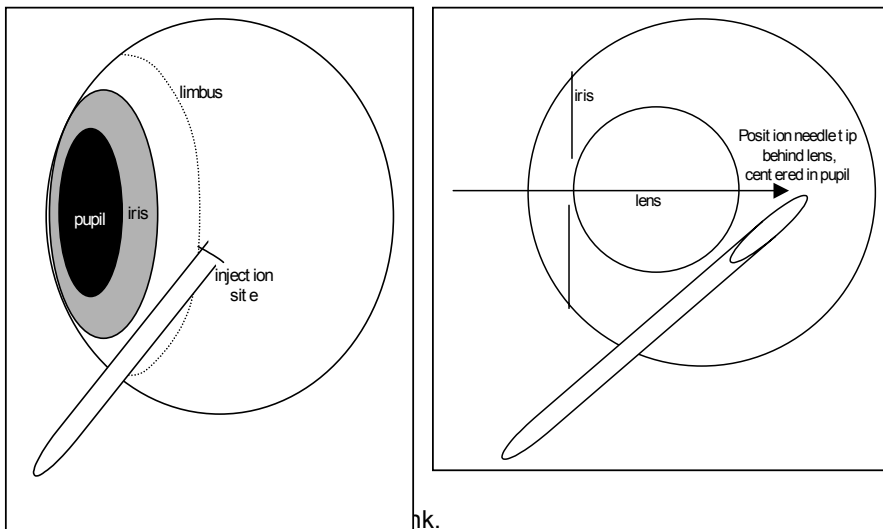

- transect with a #11 scalpel (start at a point slightly below the spinal cord and just posterior to the operculum, insert perpendicular to the plane of the fish and rock down to quickly cut). Make 3-4 radial cuts around the eye to open up the orbit and remove each eye. Open the anterior chamber to allow fixative access and immerse. Then open the cranium by removing the top of the head with saggital cuts along the parietal plates and aspirate the fat from with brain with a plastic pipette. Use a surgical spatula to scoop from the caudal to rostral direction, gently cutting the cranial nerves and lifting out the brain to fix.

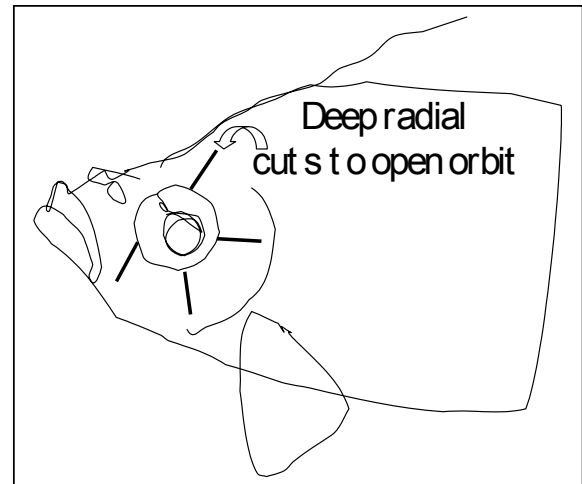
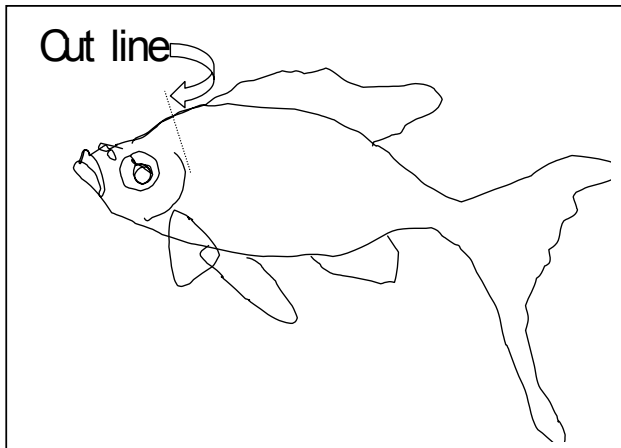

Rabbit Retinal Incubation Protocol

Supply list

Solutions:

Saline 4: HEPES-Ames medium equilibrated 100% O₂
Reagents for pharmacology prepared for dilution with Ames medium
Fixative 1 for rabbits: 2.5% GA/1% PF in 0.1 M PBr + 3% sucrose (20 vials = 100 ml)
15% urethane in H₂O
100% O₂ lines (saline, incubation wells, pharmacologics)

Field:

37° C bath
37° C plate
Blue pads
Plastic bag and ties
Multichannel timers
Gauze or tissue for packing
Paper towels for blotting
Whatman filter paper

Enucleation tools:

large blunt forceps
enucleation scissors
#11 scalpel blade/handles

Dissection tools:

fine mouse toothed forceps
fine surgical scissors
carbon steel razor blades
#5 Dumont forceps
#7 Dumont forceps

Plastic & other tools:

10 ml syringes
20 ga 1½" needles
surgical gloves
nylon dissection board
100 ml tripour beakers
30 ml polyethylene cups
5 µm cellulose acetate filters
60 mm Petri dish bases
10, 25, 100, 1000 µl pipetters & tips
lg & sm disposable pipets
Scintillation vials
Paper labels
#2 pencil
Bloc logbook
China marker

Rabbit Retinal Incubation Procedures

1. The day before the procedure, call the ARC and schedule a rabbit for 9 AM.
2. Pick the tranquilized rabbit up at 9 AM and record the weight (Kg):
3. Quickly transfer the animal to the physiology room and place in a polyethylene bag on a blue pad with the right side of the head up, out of the bag.
4. Inject the rabbit IP with 30 cc 15% aq. urethane thru a 1½ " 20 Ga needle. Make sure it is IP, not SQ.
5. After 15 m assess anesthesia level with toe pinch. If there is no response (respiration rate change), go to step 6. If there is, apply a 2nd 30 cc dose, wait 15 m and check. If there is no response, go to step 7.
6. Inject the rabbit IP with a 2nd 30 cc dose of 15% aqueous urethane; euthanize via bilateral thoracotomy.
7. Enucleate the right globe and pack the socket, turn the rabbit over and enucleate the left globe.
8. Quickly strip all fat off the eye and cut the optic nerve head flush to the globe.
9. Slice each globe posterior to the ora with a razor and remove the anterior segment (Fig. 1).
10. Cut the eyecup into a Maltese cross with and gently spread on the board (Fig. 2).
11. Remove vitreous by wicking with Kimwipe points. Do not touch retina (Fig. 3).
12. Cut the eye into nasotemporal strips (Fig. 4).
13. Slide each strip onto a wax sheet and place a piece of Millipore filter on the vitreal surface of the retina. Make sure the filter is larger than the strip. (Fig. 5)
14. Invert the assembly onto filter paper and allow any extra vitreous to wick away (Fig. 6).
15. Grasp the sclera with #5 Dumont forceps and lay the blunt backside of a #7 Dumont forceps on the filter. Gently peel the sclera/RPE away (Fig. 6). If the RPE leaves patches, leave them alone.
16. Place the strips of retina in a Petri dish containing warm, freshly oxygenated Ames medium. Do not agitate or bubble. Cover with a gassed lid.
17. Retrieve a strip, cut into chips as desired, incubate and fix.

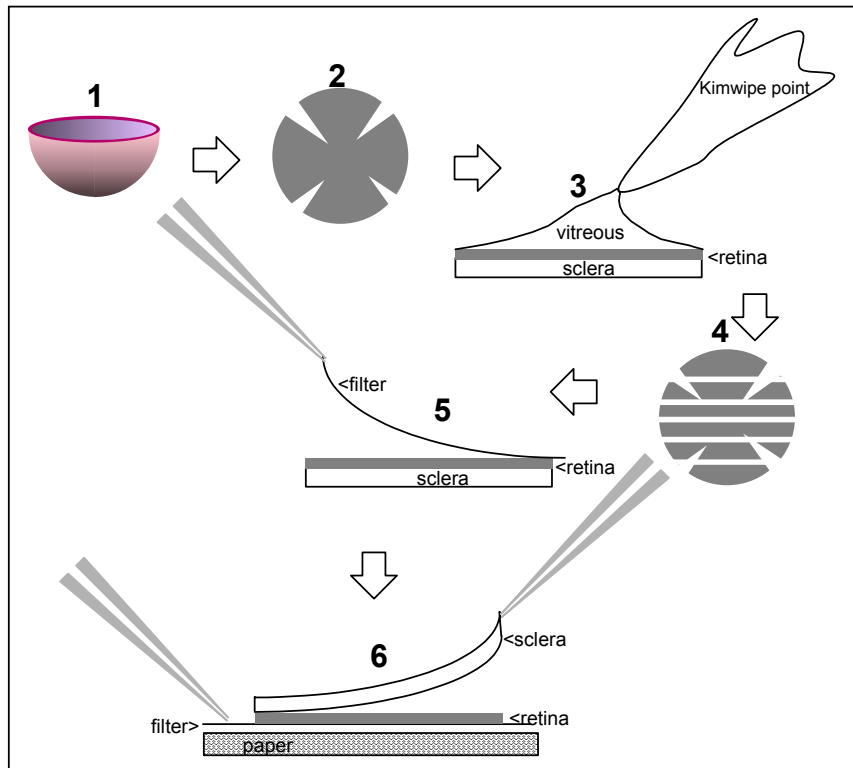

Autoradiography Protocol

Modified from Bok, 1975; Marc, 1980; 1995 Revision

Sections:

Cut 500 nm sections (pinkish-green) of epoxy embedded specimen. Pick up ribbon with a natural bristle (not nylon) and place on a droplet of deionized H₂O on a clean slide. Keep the sections away from the labeled end of the slide. Ideally, sections should be clustered at the same location on all slides, about 4-5 cm from the labeled end. Dry briefly on a hot plate at about 65-80° C. Do not overdry, merely evaporate the water or the sections may crack excessively. Store in a dust free box.

Deplasticize:

Deplasticize the sections for 7 m in Na ethoxide solution.

Materials for dipping slides:

- Clean, light-proof darkroom
- Kodak NTB2 or NTB3 emulsion
- Wooden spatulas (Junior tongue depressors)
- Blank clean slides
- 3M black opaque photographic tape
- 40 ° C water bath
- Container for dipping slides
- Slide drying rack with lid
- Paper towels and Kimwipes
- Sodium vapor lamp
- Blue pad or other surface liner
- Slides

Record-keeping:

Record each slide number and its intended location in the drying rack and its exposure box on a data sheet. **Do not forget to do this.**

Melting the emulsion:

1. Use the following design to melt emulsion. The vessel should be have the same cross-sectional area at all heights. Glass works fastest and is easiest to clean but plastic will suffice. The melting and dipping vessels may be different containers. Here we will presume the same vessel to be used for both. The measurements refer to heights for dipping conventional 75 mm (3 in) long slides

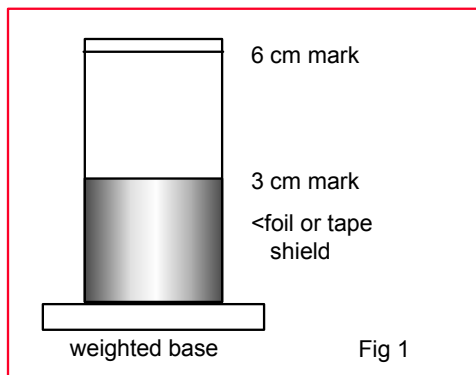

2. Fill to the 3 cm level with dH₂O and warm to 40 °C
3. Turn on the sodium lamp with the orange vanes open about 1/3 (use both yellow and orange filters). Do not turn the lamp off until everything is complete. Turn off fluorescent darkroom lights.
4. Open the emulsion and gently spoon out sufficient emulsion with the wooden spatula to fill the container to 6 cm. Check this by viewing the container silhouetted by the sodium light, at least 6 feet away, with the emulsion itself protected by foil or tape (it will sink). Return the stock emulsion gel to the refrigerator as soon as possible. Allow the container to warm in the water bath for 20 m.
5. After 20 m, stir the emulsion gently but thoroughly. Allow it to warm another 20 m to permit degassing of the gelatin.
6. Dip blank slides in the emulsion and check the density of bubbles. There will be many at first. Use the procedure in Fig 2 to clear the emulsion of bubbles. If the emulsion is not reasonably clear (< 5 small bubbles) after ten dips, allow to warm another 10 m and repeat. **Do not skip this step.**

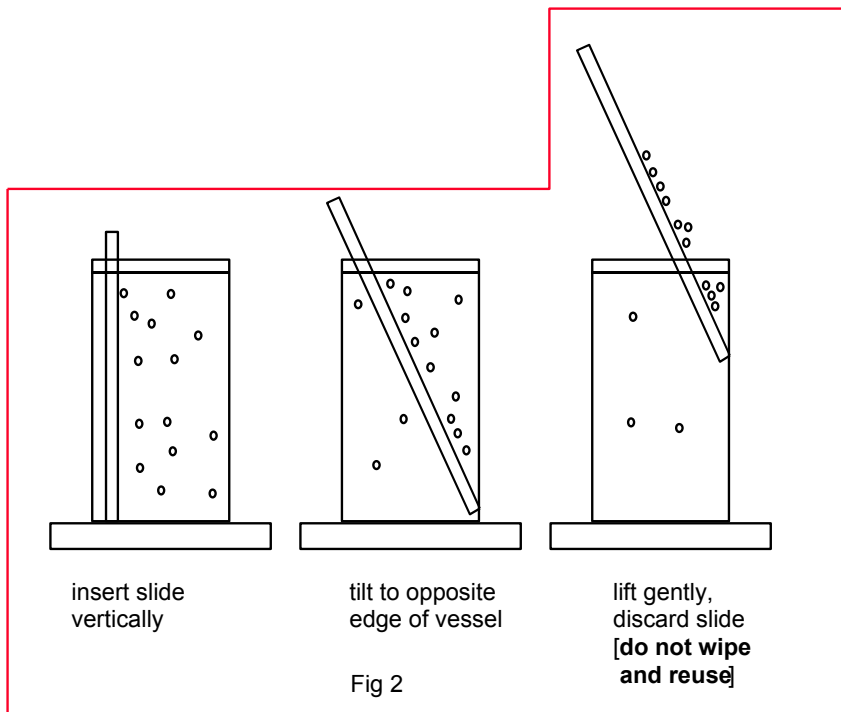

Dipping slides:

1. Set up the drying rack next to the water bath.
2. Dip slides vertically, immersing for 1 s, and withdraw gently (about 2 s). Touch the end of the slide to a paper towel or Kimwipe then place in the drying rack. Do not mix the order of the slides or the data sheet will not mean anything. Place the drying rack inside a container (old photo paper box, a cabinet in the darkroom or a custom container that can be kept dark but has enough airflow to permit drying) and allow the slides to dry in total darkness for three h.

Note: A drying rack is best constructed from heavy Plexiglas and consists of a series of wall against which slides can be placed at an angle of 60-72° from horizontal (Fig 3). The heavy Plexiglas prevents knocking a large set of slides over by inadvertently bumping the rack and it can be easily washed in hot water. A quick rack can be made from a standard 100 slot slide box by placing blank slides in the box every 3-4 spaces to provide a 60-72° drying angle.

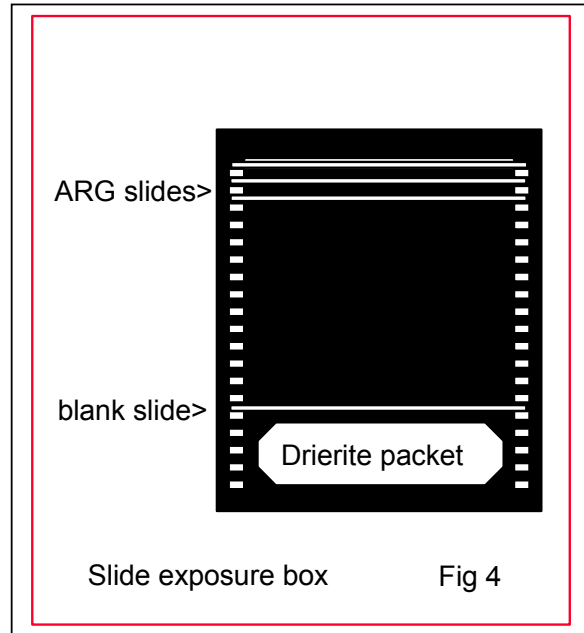
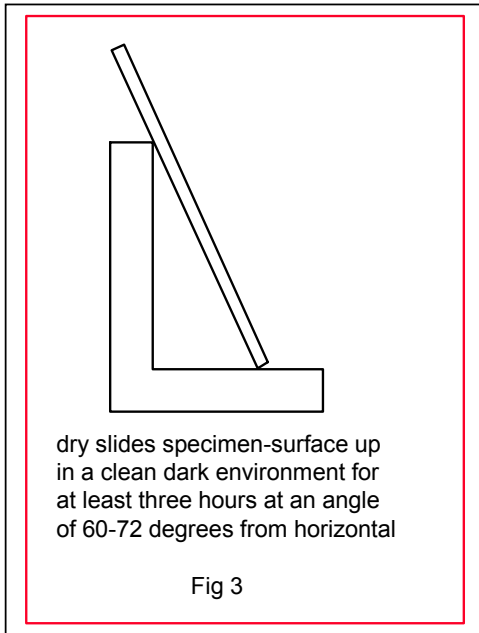

Storage:

1. While the slides dry, prepare storage boxes (Fig 4). Label the box tops now.
2. Use black plastic or heavy opaque white polycarbonate style boxes that hold 20-30 slides. Do not use the soft, polyethylene boxes with integral tops. They leak light.
3. Place 2 Drycaps or 1 Drierite packet behind a blank slide in each box. For the latter, place 1/2 tsp Drierite in the center of an unfolded Kimwipe, fold loosely to make a packet and staple the ends.
4. Under the sodium light quickly load slides, label to the left, in sequence from back to front. This is because I am left handed. Whatever procedure you use, be consistent. If you are preparing autoradiographs for me, use the left hand rule.
5. Put the cover on the box, seal in 2 wraps of black darkroom tape ensuring that all edge seams are tightly sealed. Store in refrigerator for the time required by dosage.

Supplies for development

- Clean, light-proof darkroom
- exposed slides
- large ice tray with crushed ice in water
- 3 container processing rack or 3 glass slide trays
- Kodak D-19 developer
- 5% acetic acid in dH₂O
- Kodak Acid Fixer (not Rapid Fix)
- Sodium vapor lamp
- Thermometer
- Running cool water

Development and processing:

1. After a suitable exposure interval, one representative slide from a group is developed, fixed and examined. This will provide information for calculating the exposure required for the rest of the slides. Retrieve the slides from the refrigerator and turn on the sodium lamp to warm it up.
2. The darkroom should be set up with a three tray wire rack in a large developing tray containing ice water.
3. *Solution 1:* 100% filtered Kodak D-19.
4. *Solution 2:* 5% acetic acid in dH₂O
5. *Solution 3:* 100% filtered Kodak Acid fixer (do not use Rapid Fix)
6. When the temperature of each solution reaches 17°C, remove the rack from the ice and begin immediately. The temperature of the developer controls the size of the silver grains.
7. Turn off the fluorescent lights, open the slide box and place the slides in the carrying rack or tray. **Work quickly.**
8. Immerse in developer for exactly 2 m. Gently raise and lower the carrier every 30 s.
9. Transfer directly to the stop bath for 10 s.
10. Transfer to fixer for 2 m, raising and lowering the slides every 15 s. After 2 m the slides should be transparent rather than opaque white. At this point, the room lights may be turned on. Leave the slides in the fixer for another 8-10 m.
11. Rinse the slides in gently running tap water for one h. You may use hypo clear (standard 20% strength, as for film) for 5 m and reduce the wash to 10 m.
12. Rinse briefly in distilled water and dry 12 h in a dust-free environment.
13. Stain the slides by placing a small droplet of toluidine blue stain directly over the sections on a hot plate at 65-80 °C. Heat the sections until you can clearly see the staining. Rinse in two quick changes of dH₂O and air dry for at least 3 h before cover slipping. For archival preparations, place a droplet of activated epoxy resin on each patch of sections and cover with a weighted cover slip Do not epoxy the weight to the slide. Polymerize at 60-65 °C overnight.

Marc Laboratory ICC Slide Records: Slide #s _____

Slide #	Stack/Bloc #

1	3	5	7	9	11
2	4	6	8	10	12

- Standard silver for all
- Standard Cy3 for all
- Deosmication required for slide #:

Notes for other conditions
